

d|abla

MADE STUDIO
VENT

SILLA MODELO 1 - SILLA MODELO 1

PT14857



MATERIALES - MATERIALS

Fabricada con acero zincado termolacado y poliuretano rígido lacado.

Made of powder coated galvanized steel and stiff lacquered polyurethane.

DATOS TÉCNICOS - TECHNICAL DATA

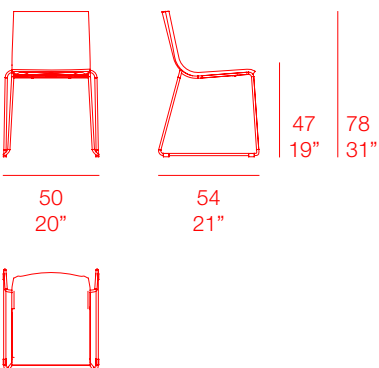

📦 7,5 kg - 16,50 lbs
📦 0,21 m³ - 7,41 ft³



Apilable. Stackable
Máx. 3 unidades / Max. 3 units.

diabla

MAINTENANCE - MANTENIMIENTO

Ver apartado de limpieza y mantenimiento: www.diablaoutdoor.com

See cleaning and maintenance section: en.diablaoutdoor.com

COLORES - COLOURS

Estructura. Frame

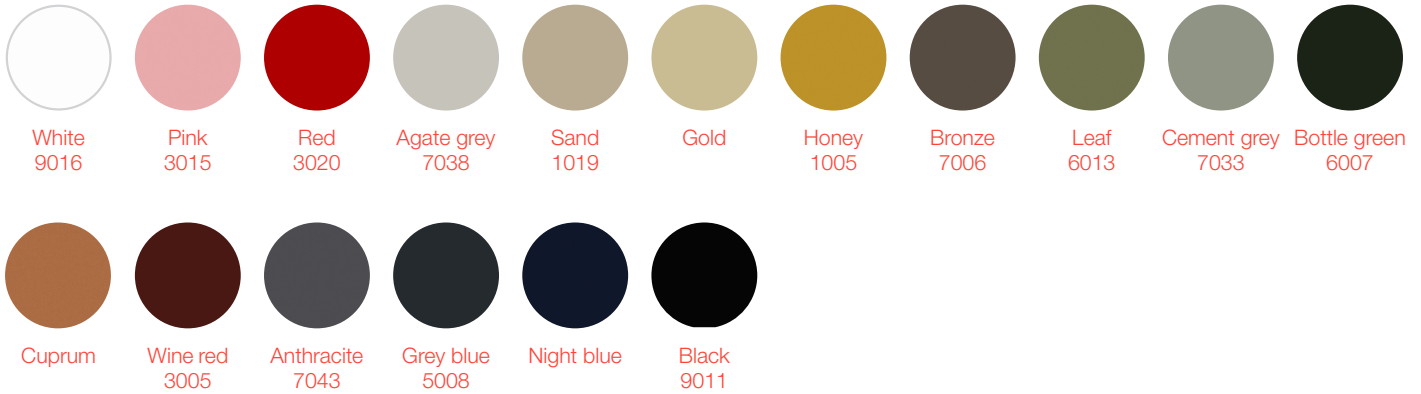

Poliuretano. Polyurethane

